

# TERRACELL®

## CELLULAR CONFINEMENT SYSTEM



**TerraCell** is an innovative geosynthetic product providing solutions for difficult stabilization, erosion control, slope and retaining wall challenges. TerraCell, generically referred to as a “**geocell**,” confines native or select fill materials and is the integral component of a **cellular confinement system**.

TerraCell is a lightweight, flexible mat made of high density polyethylene strips. These strips are ultrasonically bonded together to form an extremely strong, honeycomb configuration. A variety of fill materials can be placed within the TerraCell system: soil, sand, aggregate, concrete, etc. The use of TerraCell and the appropriate fill material create numerous opportunities for versatile and economical solutions for many applications including:

- GROUND STABILIZATION
- SLOPE EROSION CONTROL
- RETAINING WALLS
- STREAM CROSSINGS
- CHANNEL EROSION CONTROL
- EMBANKMENTS

To satisfy the application, TerraCell is available in various heights and three different cell sizes: TerraCell 140 (small), TerraCell 175 (intermediate) and TerraCell 280 (large). It can be supplied in solid wall or perforated (to allow flow between cells) styles. Holes can be made in TerraCell to facilitate a tendoning system for some applications. TerraCell can be manufactured into custom sizes for specific requirements (i.e.; retaining wall fascia).



## EXPANDED DIMENSIONS

### - TerraCell 140

8.4 ft. x 21.4 ft. x cell height  
 Panel Area: 180 sq. ft. (nominal)  
 Cell Area: 10.2" x 8.8"  
 (44.8 sq. inches nominal)

### - TerraCell 175

8.4 ft. x 27.4 ft. x cell height  
 Panel Area: 230 sq. ft. (nominal)  
 Cell Area: 12.6" x 11.3"  
 (71.3 sq. inches nominal)

### - TerraCell 280

8.4 ft. x 45 ft. x cell height  
 Panel Area: 378 sq. ft. (nominal)  
 Cell Area: 20.0" x 18.7"  
 (187 sq. inches nominal)

## CELL HEIGHT

8", 6", 4", and 3"

## COLOR

Black

## CUSTOM COLORS

Tan and Green

## TERRACELL 140

nominal panel size

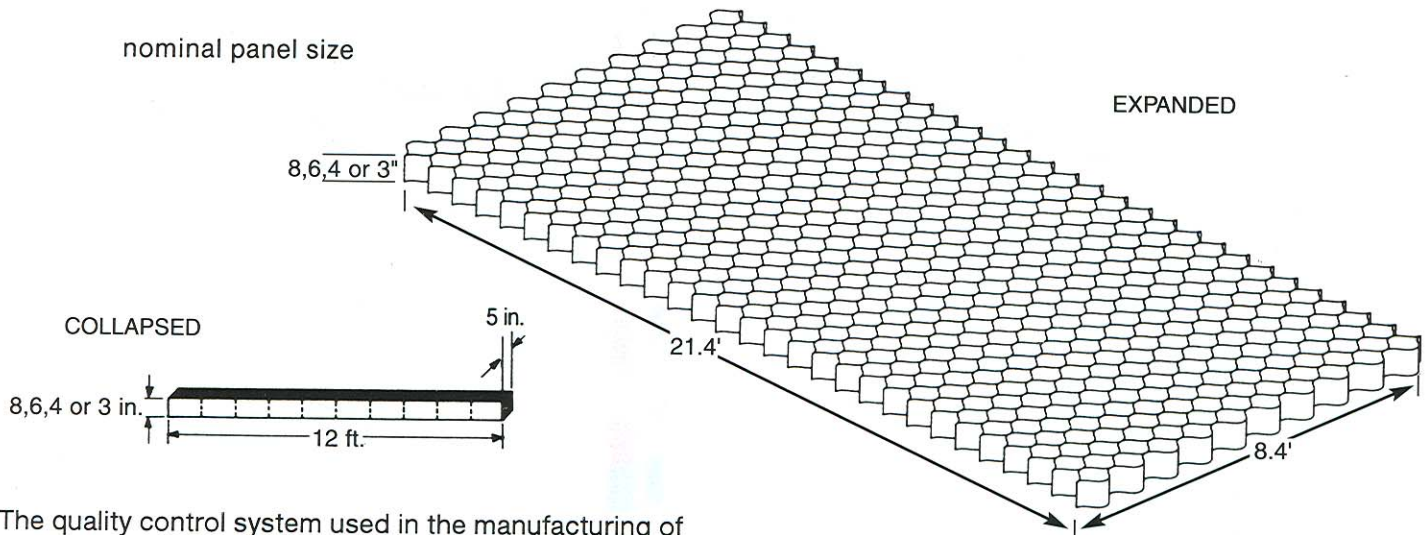

## TERRACELL PRODUCT SPECIFICATIONS

TerraCell is manufactured from High Density Polyethylene (HDPE) to the following minimum standards:

PROPERTY	TEST METHOD	VALUE
Sheet Thickness	ASTM D-5199	50 mils, ± 5%
Density	ASTM D-1505	0.94 grams/cubic cm
Carbon Black Content	ASTM D-1603	1.5%
Environmental Stress Crack Resistance	ASTM D-1693	4000 hours

Cell joints are ultrasonically spot-welded with three (3) welds per inch uniformly spaced across the height of each strip. Seam strengths are the same across the entire height of the cell joint and meet the following minimum seam peel strengths (per US Army Corps of Engineers Technical Report GL-86-19, Appendix A).

CELL HEIGHT	SEAM PEEL STRENGTH	APPROXIMATE WEIGHT
8 Inch	640 lbs.	114 lbs.
6 Inch	480 lbs.	86 lbs.
4 Inch	320 lbs.	57 lbs.
3 Inch	240 lbs.	43 lbs.

Seam Hang Strength—A 102 mm (4.0 in.) weld joint supporting a load of 72.5 kg (160 lbs.) for 30 days minimum or a 102 mm (4.2 in.) weld joint supporting a load of 72.5 kg (160 lbs.) for 7 days minimum while undergoing temperature change from 23°C (74°F) to 54°C (130°F) on a 1 hour cycle.

Installation Temperature Range: 16°F to 110°F

The quality control system used in the manufacturing of TerraCell is in compliance with ISO 9001:2000 standards. TerraCell is licensed from the United States Army under Patent No. 4,797,026.

TerraCell and WEBTEC's broad line of geosynthetic products are marketed through a network of local distributors.



P.O. Box 19729 • Charlotte, NC 28219  
 (800) 438-0027 • (704) 398-0954  
 Fax (704) 394-7946  
 E-mail: Info@WEBTECGEOS.com  
 Website: www.WEBTECGEOS.com

International Erosion Control Association



Corporate Member



The facts stated and the recommendations made herein are offered free of charge and are accurate to the best of our knowledge. However, no guarantee of their accuracy is made and the products mentioned are distributed without warranty, expressed or implied. Final determination of the use of any information or material, or how it is used, and whether the use infringes any patents, is the sole responsibility of the user.